

Installation and Operating Instructions

ES-AH11

Environmentally Friendly
MERCURY FREE!!

Use **ONLY** ACCUSTAT®
Independence
Temperature Setpoints

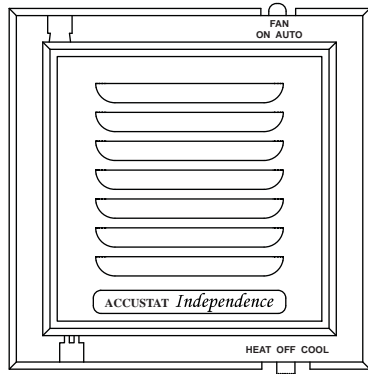

Application:

The ACCUSTAT® *Independence* model ES-AH11 thermostat was designed to operate 24VAC to 30VAC single stage heating and cooling systems. This thermostat is MERCURY FREE!! The ACCUSTAT® *Independence* models utilize pre-set plug-in temperature setpoints to activate the circuits. Room air temperature is measured by a micro-processor and compared with the plug-in setpoint temperature. This thermostat can operate in heat only, cool only or be off. The fan cycles on/off with calls for heating or cooling or can be on continuously. The thermostat has a locking cover to prevent tampering.

Operating Conditions:

The electronic mechanisms incorporated within this unit REQUIRE operating conditions similar to other electronic devices intended for INDOOR USE ONLY, such as would be acceptable for TV and similar household appliances. Relative humidity must be less than 95% and the atmosphere must be non-condensing. Air quality must be maintained, FREE of heavy dust or debris which may infiltrate the interior of this device. Installation in any space which is unfinished or undergoing repainting or general rehabilitation is also considered product abuse. This device should be removed from service during any local construction activity.

Cleaning:

This device incorporates a high impact styrene enclosure which is easily cleaned with a dry cloth or vacuum brush. Occasional soiling may be cleaned with a soft cloth lightly dampened with water and/or mild cleaning solution. IN NO CASE should this device be directly sprayed with or exposed to free flowing liquids, including water, which could penetrate its interior.

FAILURE TO OBSERVE ANY OF THE ABOVE CONDITIONS OF USE WILL COMPLETELY VOID THE SUPPLIER WARRANTY.

CAUTION

MAKE SURE UNIT IS PROPERLY CONNECTED. DAMAGE TO THE CONTROL CAN BE CAUSED BY MISWIRING, WHICH WILL VOID THE WARRANTY.

Specifications:

- Set Temperature Range:** Determined by plug-in setpoint
- Plug-in Setpoint Accuracy:** $\pm 0.5^\circ$
- Control Accuracy:** $\pm 1.0^\circ$
- Sampling Rate:** Every 30 seconds
- System:** Switch selectable, heat only, cool only or off
- Stages:** Single stage heating/cooling
- Differential:** Switch selectable, 0.5° or 1.0°
- Fan:** Switch selectable, auto cycle or continuously on
- Operating Temperature:** 14°F to 105°F
- Storage Temperature:** -4°F to 105°F
- Input:** 20VAC to 32VAC
- Load Rating:** 1 amp maximum per circuit, 80mA minimum for energy harvesting
- Cycle Rate:** 6 cycles per hour
- Common Wire:** Optional
- Delay:** 5 minutes on start-up
- Energy Harvesting:** Switch selectable, on or off
 - Enable switch if not connecting a common wire
 - Disable switch for sensitive loads, common wire will then be required
- Thermostat Charge:** Thermostat will hold its charge 3.5 hours during a power failure
- Enclosure:** High impact styrene, white
 - Case can be locked, key required

TO OPEN:

1. Align key with slot and insert all the way
2. Locking pin will emerge. Pull out completely
3. Gently squeeze left side of cover to release catches
4. Let right side work as a hinge
Swing cover out and remove

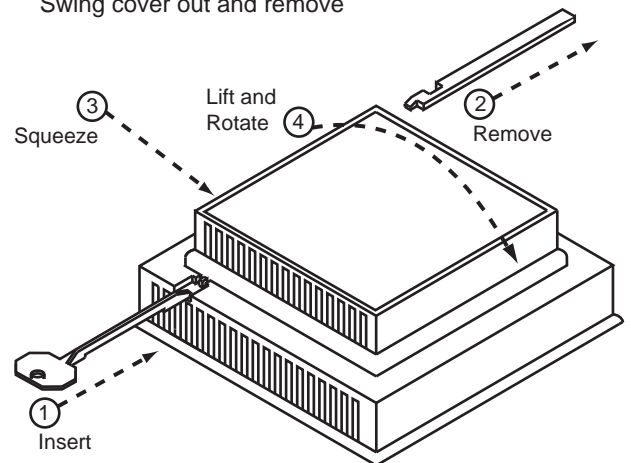

TO CLOSE: (Reverse Procedure)

1. Hinge right side of cover and close it
2. Gently squeeze left side of cover and snap shut
3. Orient the locking pin as shown and slide in until end is below surface of cover (audible snap is heard when pin is properly seated)

ATTENTION: This product does not contain mercury. This product may be replacing a product containing mercury. Do not place the old product in the household trash. For more information on recycling and proper disposal visit TRC's website www.thermostat-recycle.org Should a tube break, do not touch any spilled mercury. Wear non-absorbent gloves, collect any spilled mercury and place it in a sealed container. Contact your local waste management authority for recycling and proper disposal instructions.

GENERAL INSTRUCTIONS:

This control should be installed and serviced by a qualified contractor.

1. **▲ Caution:** Make sure that power to the control has been turned off before doing any installing or service work. Class 2 transformers can be damaged if a short circuit occurs when disconnecting wires from the old thermostat.
2. All wiring must conform to local and state codes and ordinances.
3. A thorough check-out of the system must be made after the control has been installed.
4. This thermostat was designed to operate as a energy harvesting control. A common wire is optional. If the thermostat is connected directly to a logic board at the equipment, in order for it to function, it may be necessary to connect a common to the thermostat and turn off the energy harvesting switch.

MOUNTING THE CONTROL:

1. Open case as shown.
2. Choose a location about 5 feet above the floor, in an area where there is good air circulation. Such an area will provide an average room temperature.
3. Do NOT mount thermostat where it may be affected by drafts, hot or cold air from ducts or radiant heat from the sun or appliances.
4. Pull thermostat cable through hole in wall or outlet box.
5. Plug wall hole to prevent drafts which may affect thermostat.
6. Use the screws supplied to mount the case on the wall.
7. This control is not position sensitive. However, heat rises and some heating does occur in the control. It is recommended that the unit be mounted with the top up.

INSTALLING PLUG-IN SETPOINTS:

Installing the pre-set plug-in temperature setpoints is as easy as installing a fuse. Direction does not matter. The large plated tabs must be pointed toward the thermostat. Press the plug-in setpoint firmly into position.

NOTE: The plug-in setpoints must be installed at all times.
Removal of the setpoints will disable the thermostat.

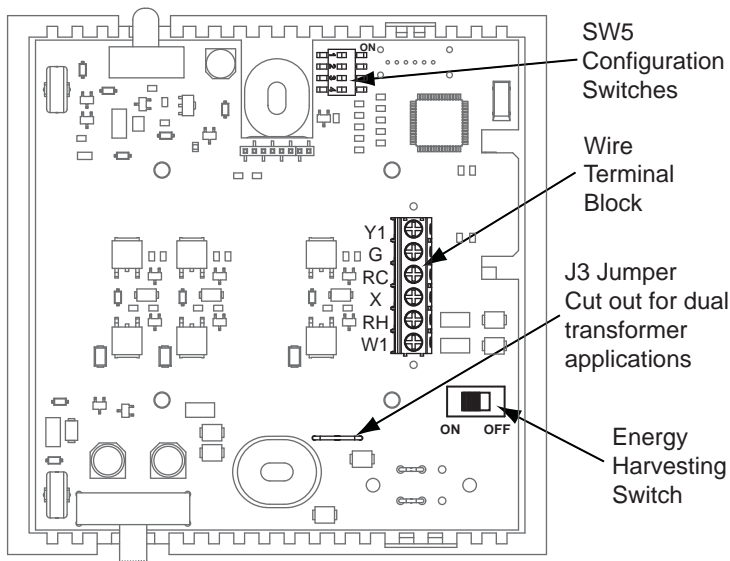
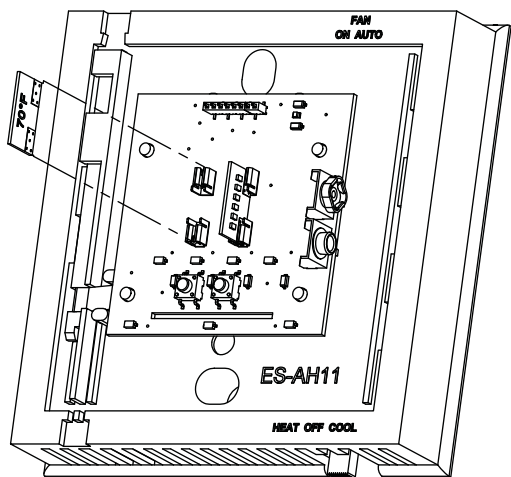

NOTE: RC and RH are internally connected by J3 Jumper. For dual transformer application cut and remove J3 Jumper.

SW5 Settings:

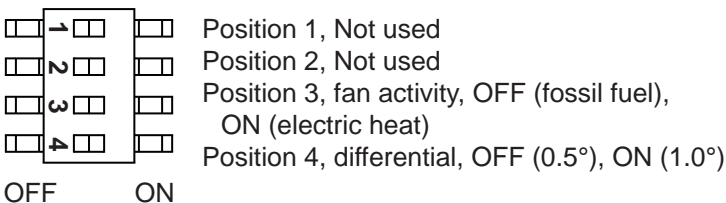

PSG Controls, Inc.
LIMITED WARRANTY POLICY

PSG Controls, Inc. (Hereinafter referred to as "PSG") warrants the following:
 Only cataloged products sold to distributors are warranted to the original purchaser, to conform with specifications furnished or approved by PSG, and to be free from defects in material and workmanship, for a period of one (1) year from the date of purchase, unless specified in writing for a different period.
 Any PSG product that proves defective within the above described warranty period will be repaired or replaced (at PSG's option) free of any charge if returned to the PSG factory at 1225 Tunnel Road, Perkasie, PA. 18944 with transportation charges prepaid. Prior to returning this product to PSG, the purchaser shall give PSG notice in writing stating how this product fails to fulfill this warranty. No product shall be accepted for repair or replacement without a required written notice and without prior written authorization and shipping instructions having been received by the purchaser from PSG. Only PSG's factory is authorized to perform services under this warranty.
 This warranty does not extend to any product that has been subjected to misuse, abuse, neglect, accidents, alterations, improper installation or use in violation of the printed instructions furnished by PSG. This warranty neither applies to batteries nor deterioration of, nor damage to the product caused by the use of faulty batteries. Final determination as to whether any product is actually defective rests solely with PSG.
 This warranty is expressly in lieu of all other agreements and warranties, expressed, implied, or statutory and PSG has no other obligations or liabilities in connection with this product. In no event shall PSG's obligation or liability hereunder exceed the purchase price of this product. **PSG SHALL NOT IN ANY EVENT BE LIABLE FOR ANY INCIDENTAL OR CONSEQUENTIAL DAMAGES.** This warranty gives you specific legal rights, and you also have other rights which vary from state to state. Some states do not allow the exclusion or limitation of incidental or consequential damages, or implied warranties, so the above limitations or exclusion may not apply to you.

Toll free technical assistance is available
 via our technical hotline: 1-800-523-2558
 Mon-Fri, 8:00 A.M. to 4:30 P.M. Eastern Standard Time



Conventional System (Single Transformer)

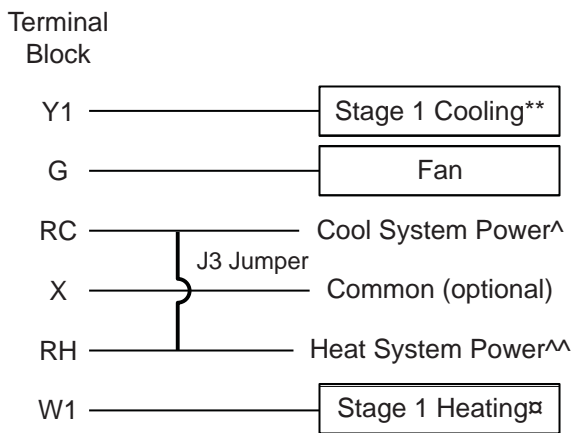

SW5 Settings:

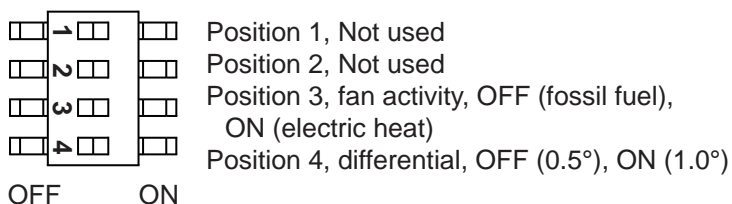

Operating with a common wire connection:

If installing the thermostat with a common wire connection, place the ENERGY HARVESTING switch in the OFF position. Upon first power up or following a power failure the thermostat will run under normal operating conditions within 5 minutes.

Operating without a common wire connection:

If installing the thermostat without a common wire connection, do the following:
Prior to mounting the thermostat –
Place the ENERGY HARVESTING switch in the ON position.

At first power up or following a power failure it may take the thermostat 7 to 20 minutes for the power harvesting circuitry to charge before going into the first heating or cooling call.

An optional method of bypassing the 7 to 20 minute wait is to connect a 9V battery to the sensor board battery terminals.

LED D1 will light once the battery is connected.

When done charging the LED will become dim or go off (approximately 2 minutes).

Remove battery and the thermostat will run under normal operating conditions within 5 minutes.

While the battery is attached the unit may be tested as stated to the right.

NOTE: The thermostat will not attempt to control temperature until the battery is removed

** For Y1 to be active, plug-in setpoint is required in C1 position

^ If dual transformers are used, the J3 jumper must be cut

^^ Only required if dual transformers are used.
For single transformer applications, it is not necessary to connect RH. The J3 jumper must be connected.

⌘ For H1 to be active, a plug in setpoint is required in H1 position

IMPORTANT NOTICE TO INSTALLERS TESTING:

To place thermostat in test mode insert 9 volt battery into sensor board battery terminals.

If storage capacitors are not charged a light will come on in the upper right corner.

NOTE: To test, plug-in setpoints are required.

Prior to the test verify that your SW5 switch settings are set correctly per your application.

Cooling:

C1 setpoint must be installed.

HEAT/OFF/COOL switch must be in the COOL position.

1. Press the "B" button.
Fan (G) and cooling (Y1) will turn on.
2. Press the "B" button again.
All outputs will turn off and cooling test is complete.
Proceed to heating test, if necessary, or remove battery to end testing.

Heating:

H1 setpoint must be installed.

HEAT/OFF/COOL switch must be in the HEAT position.

1. Press the "C" button.
Heat (W1) will turn on.
If SW5 switch position 3 is ON (electric heat) fan (G) will also turn on.
2. Press the "C" button again.
All outputs will turn off and heating test is complete.
Proceed to cooling test, if necessary, or remove battery to end testing.